

CLARKE®

STRONG-ARM

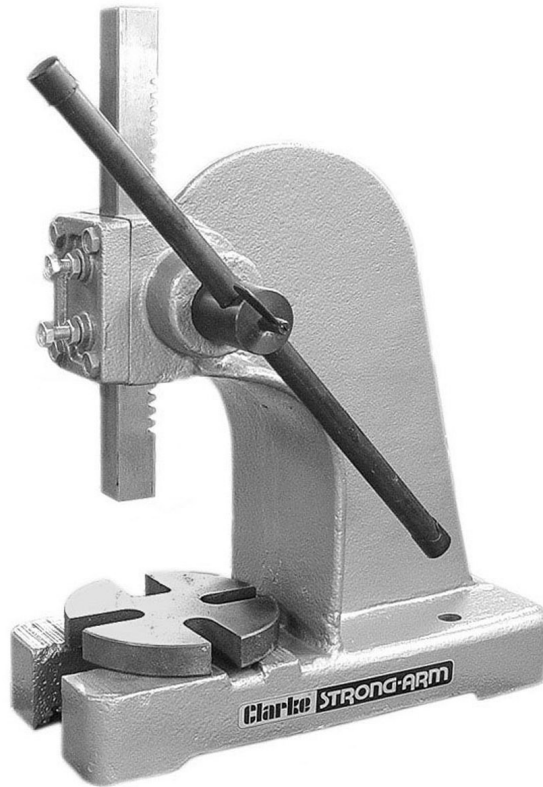

GC0122- rev 2

ARBOR PRESS

Model No's AP500B & AP1000

Thank you for purchasing this CLARKE Arbor Press, which is designed for trade use.

Please read this instruction sheet thoroughly and follow the instructions carefully. In doing so you will ensure the safety of yourself and that of others around you, this will also ensure that the Arbor Press will give you long and satisfactory service.

Please keep these instructions in a safe place for future reference.

CLARKE GUARANTEE

This CLARKE product is guaranteed against faulty manufacture for a period of 12 months from the date of purchase. Please keep your receipt as proof of purchase.

This guarantee is invalid if the product is found to have been abused or tampered with in any way, or not used for the purpose for which it was intended.

Faulty goods should be returned to their place of purchase, no product can be returned to us without prior permission. This guarantee does not effect your statutory rights.

SAFETY PRECAUTIONS

As with all machinery, there are certain hazards involved with its operation and use. Exercising respect and caution will considerably lessen the risk of personal injury. However, if normal safety precautions are overlooked or ignored, personal injury to the operator or damage to property may result.

- **BEFORE** use, secure the press to a suitable work bench.
- **ALWAYS** keep fingers clear of moving parts.
- **ALWAYS** wear safety goggles, manufactured to the latest European Safety Standards. Everyday glasses do not have impact resistant lenses, they are NOT safety glasses.
- **ALWAYS** keep work area clean. Cluttered areas and benches invite accidents.
- **ALWAYS** ensure that adequate lighting is available. A minimum intensity of 300 lux should be provided. Ensure the lighting is positioned where you will not be working in your own shadow.
- **ALWAYS** concentrate on the job at hand, no matter how trivial it may seem. Be aware that accidents are caused by carelessness due to familiarity.
- **ALWAYS** wear proper apparel. Loose clothing or jewellery may get caught in moving parts. Wear protective hair covering to contain long hair.
- **NEVER** operate the press when under the influence of drugs, alcohol or any medication.
- **NEVER** force the press; it will do a better and safer job at the rate for which it was designed. Do not attempt to apply more leverage by extending the length of the handle.

TECHNICAL SPECIFICATIONS

Model No	AP500B	AP1000
Part No	7615172	7615175
Rated Force*	0.5 ton	1.0 ton
Dimensions (L x W x H)	255 x 120 x 280 mm	270 x 129 x 439 mm
'A'	75 mm	90 mm
'B'	112 mm	138 mm
'C'	117 mm	140 mm
'D'	17 mm x 17 mm	23.6 mm x 23.6 mm
'E'	95 mm	118 mm
'F'	295 mm	349 mm
Weight	9.3 kg	15.0 kg

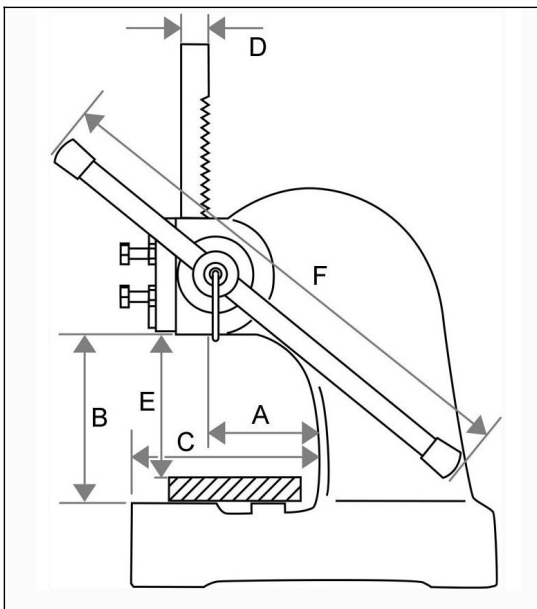

* Rated force dependant on exerted load.

WARNING: The use of spare parts or accessories, other than those supplied by CLARKE international or one of its recognised dealers, may be hazardous and could invalidate the guarantee.

PARTS AND SERVICE

Clarke[®]
INTERNATIONAL

For spare parts and servicing, please contact your nearest dealer, or

CLARKE International on:

020 8988 7400

or email:

Parts@clarkeinternational.com

Service@clarkeinternational.com

CLARKE International, Hemnall Street, Epping, Essex, CM16 4LG